



## Room Thermostat

## RAA30...

Adjustable room thermostat for heating only or cooling only systems

---

**Room thermostat with manual ON/OFF switch**  
**Two-position control**

### Use

The RAA30... room thermostat is used in heating only or cooling only systems to maintain the selected room temperature.

Typical use:

- Residential buildings
- Light industrial buildings

In conjunction with

- zone valves, thermal valves
- gas or oil burners
- fans
- pumps

### Functions

<b>OFF</b>	The front of the unit carries an ON/OFF switch. When in the OFF position, the input voltage is physically separated from the output voltage.
<b>ON</b>	The RAA30... room thermostat has separate outputs for heating only and cooling only. If the room temperature falls below the selected setpoint, the heating contact will close. If the room temperature exceeds the selected setpoint, the cooling contact will close.

## Function diagrams

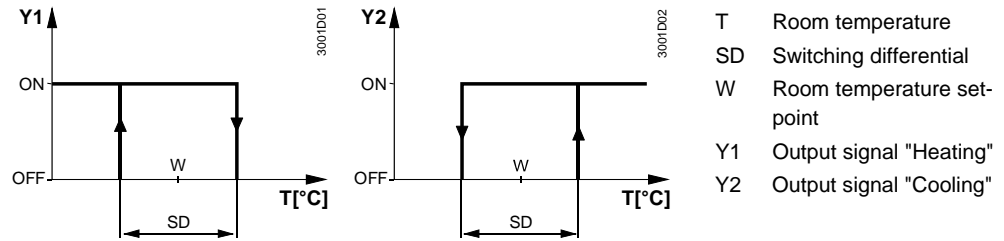

## Type summary

Functionality	Order number (ASN)
Thermostat for heating or cooling application with ON/OFF switch Operating voltage AC 24...250 V	RAA30
Thermostat for heating or cooling application with ON/OFF switch and operation mode indication (LED) Operating voltage AC 230 V + 10/-15 %	RAA30.16
Thermostat for heating or cooling application with ON/OFF switch and operation mode indication (LED) and independent ON/OFF switch Operating voltage AC 230 V + 10/-15 %	RAA30.26

## Equipment combinations

Designation	Type reference	Data Sheet
2-way zone valve DN15	MVE21.15	CE1N4828
2-way zone valve DN 20	MVE21.20	CE1N4828
2-way zone valve DN 25	MVE21.25	CE1N4828
3-way zone valve DN 15	MXE21.15	CE1N4828
3-way zone valve DN 20	MXE21.20	CE1N4828
3-way zone valve DN 25	MXE21.25	CE1N4828
Thermal actuator (suitable for radiator valves VD... / VE... / VU... and 2T...)	STE21.1	CA1N4874

## Accessories

Functionality	Order number (ASN)
Adapterplate 120 x 120 mm for 4" x 4" conduit boxes	ARG70
Adapterplate 96 x 120 mm for 2" x 4" conduit boxes	ARG70.1

## Technical design

Key features of the RAA30... room thermostat:

- Two-position control
- Manual ON/OFF switch
- Gas-filled diaphragm

## Adjustments

The required temperature is selected by a setpoint adjuster on the front of the thermostat.

The setpoint setting range can be mechanically limited by means of tappets under the unit cover.

## Notes

### Mounting, installation and commissioning

The room thermostat should be located where the air temperature can be sensed as accurately as possible, without getting adversely affected by direct solar radiation or other heat or refrigeration sources.

Mounting height is about 1.5 m above the floor.

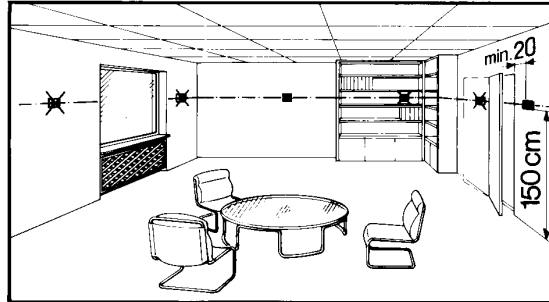

The unit can be fitted to most commercially available recessed conduit boxes or directly on the wall.



Only authorised personnel may open the unit to perform service (**Caution: AC 250 V**). The unit must be isolated from the mains supply before opening.

When installing the unit, fix the baseplate first then hook on the thermostat body and make the electrical connections. Then fit the cover and secure it (also refer to separate mounting instructions).

The thermostat must be mounted on a flat wall.

The local electrical regulations must be complied with.

If there are thermostatic radiator valves in the reference room, set them to their fully open position.

### Maintenance Mechanical design

The room thermostat is maintenance-free.

The diaphragm is filled with environmentally friendly gas.

The thermostat housing is made of plastic.

## Technical Data



Power supply

Operating voltage

- RAA30... AC 24...250 V
- RAA30.16 / 30.26 AC 230 V +10/-15 %

Power consumption of each LED  
(Only RAA30.16/30.26) 0.5 VA

Frequency 50 or 60 Hz

Operational data

Switching differential SD ≤1K

Setpoint setting range 8...30 °C

Amperage at AC 250 V 0.2...6 (2) A

Environmental conditions

Operation to IEC 721-3-3

Climatic conditions class 3K5

Temperature 0...+50 °C

Humidity <95 % r.h.

Pollution degree Normal, to EN 60730

Transport / storage to IEC 721-3-2

Climatic conditions class 2K3/1K3

Temperature -20...+50 °C

Humidity <95 % r.h.

Mechanical conditions class 2m2

Packaging single packaging / min. order 20 pieces

Norms and standards

CE conformity

Low voltage directive 73/23/EEC and 93/68/EEC

Product standard EN 60730

Safety standard	II to EN 60730
Degree of protection	IP30 to EN 60529
Screw terminals for	2 x 1.5 mm <sup>2</sup> or 1 x 2.5 mm <sup>2</sup> , min. ( 0.5 mm <sup>2</sup> )
Weight	0.14 kg
Colour of top cover	white, NCS 50502-G (RAL 9003)

## Connection diagrams

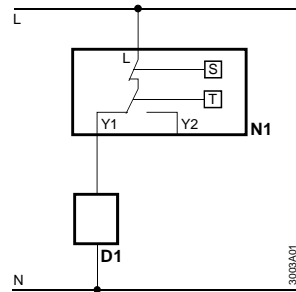

RAA30 – Heating mode

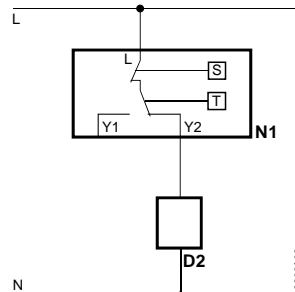

RAA30 – Cooling mode

- D1 Zone valve or thermal valve for heating
- D2 Zone valve or thermal valve for cooling
- L Operating voltage  
AC 24...250 V (only RAA30)  
AC 230 V (only RAA30.16/26)
- N1 Room thermostat
- S ON/OFF switch
- Y1 Control output "Heating",  
AC 24...250 V
- Y2 Control output "Cooling",  
AC 24...250 V
- N Neutral
- T Thermostat element  
(gas-filled diaphragm)

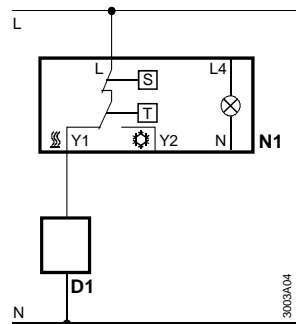

RAA30.16 – Heating mode

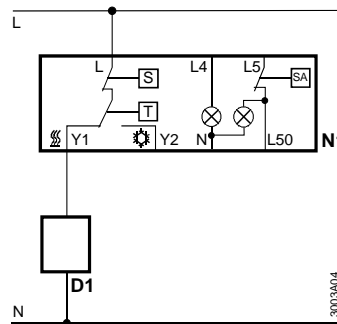

RAA30.26 – Heating mode

- L4, L5 Input
- L50 Output
- SA Auxiliary switch

## Dimensions

---

### Unit

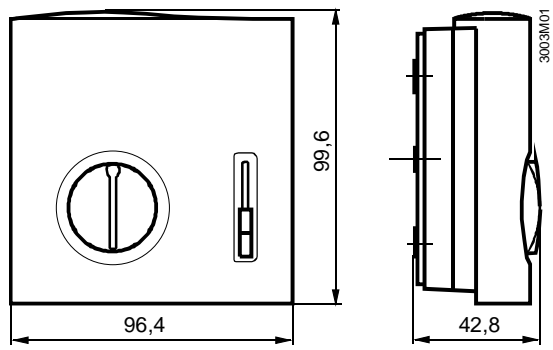

### Baseplate

