



QBM3020-..

QBM3020-..D

## Differential pressure sensor

## QBM3020-...

for air and non-aggressive gases

- High degree of measuring accuracy
- Adjustable characteristic curve (pressure-linear or extracting-the-root)
- Operating voltage AC 24 V or DC 13.5...33 V
- Output signal DC 0...10 V
- Zero-point adjustment
- Simple and fast mounting thanks to integrated fixing angle bar in the housing
- Maintenance free thanks to excellent long-term stability
- Calibrated and temperature-compensated measuring signal
- Supplied with plastic tubing
- Very short response time
- Actual value display\*

\* Depending on type

### Application

The differential pressure sensor acquires differential, over and under pressure of air and nonaggressive gases if a high degree of measuring accuracy and quality is required. It is also suited for measuring volume flow via differential pressure since the output signal can be set to extracting-the-root.

#### Fields of application

- Measuring the slightest differential pressures in ventilation and air conditioning ducts
- Check air flows
- Monitor filters and control fans
- Pressure supervision in labs, production, and clean rooms
- For acquiring variable air flow in VAV plants on the supply and extract air side

## Type summary

Type (ASN)	Product number (SSN)	Pressure measuring ranges		Output signal
		Standard	End value can be set <sup>2</sup>	
QBM3020-1U	S55720-S233	-50... +50 Pa	± (30... 50) Pa	0...10 V DC
QBM3020-1	S55720-S234	0...100 Pa	50... 100 Pa	0...10 V DC
QBM3020-3	S55720-S235	0...300 Pa	100... 300 Pa	0...10 V DC
QBM3020-5	S55720-S236	0...500 Pa	300... 500 Pa	0...10 V DC
QBM3020-10	S55720-S237	0...1000 Pa	500... 1000 Pa	0...10 V DC
QBM3020-25	S55720-S238	0...2500 Pa	1600... 2500 Pa	0...10 V DC
QBM3020-1D <sup>1</sup>	S55720-S239	0...100 Pa	50... 100 Pa	0...10 V DC
QBM3020-3D <sup>1</sup>	S55720-S240	0...300 Pa	100... 300 Pa	0...10 V DC
QBM3020-5D <sup>1</sup>	S55720-S241	0...500 Pa	300... 500 Pa	0...10 V DC
QBM3020-10D <sup>1</sup>	S55720-S242	0...1000 Pa	500... 1000 Pa	0...10 V DC
QBM3020-25D <sup>1</sup>	S55720-S243	0...2500 Pa	1600... 2500 Pa	0...10 V DC

<sup>1</sup> Type with digital display (in Pa)

<sup>2</sup> Relevant for application using extracting-the-root characteristic

Conversion 100 Pa = 1 hPa = 1 mbar)

## Ordering and delivery

When ordering a differential pressure sensor, please specify the quantity, type, and product name.

### Example

Type (ASN)	Product number (SSN)	Product designation
QBM3020-3	S55720-S235	Differential pressure sensor.

The differential pressure sensor is supplied with 2-meter plastic tubing. Additional accessories may be ordered separately.

## Accessories

Additional sets of air duct probes are available depending on measuring requirements. Various mounting brackets are also available depending on installation location.

Type	Name	Data sheet
AQB2000	Mounting bracket, for mounting sensors in isolated air ducts	N1590
AQB21.2	Top hat rail adapters (5 pieces) for DIN top hat rails, HT 35-7.5	N1590
FK-PZ1	Air duct probe, short, stainless steel, with elastic lead-through	N1589
FK-PZ2	Air duct probe, long, aluminum, with orifice plates for precise measuring requirements	N1589

## Mode of operation

The sensor acquires the differential pressure using a silicon rubber membrane and ceramic bar. Depending on the type of sensor, the sensor generates a linear or extracting-the-root signal DC 0...10 V, that is calibrated and compensated for temperature. The individual adjustment of the pressure measurement range for extracting-the-root sensors is done by means of a potentiometer.

## Mechanical design

The differential pressure sensor consists of:

- Sensor housing with mounting bracket, cable entry, and removable snap-on cover with safety screw
- Pressure chamber with membrane and ceramic lever
- PCB with terminal connections, DIP switch to switch the characteristic curve (see Commissioning notes) and potentiometer for optional end value setting on extracting-the-root characteristic (0...10 V output)
- LCD on QBM3020...D
- Zero-point adjustment button to compensate for mounting position (see "Commissioning notes")

### Display, setting and connection elements

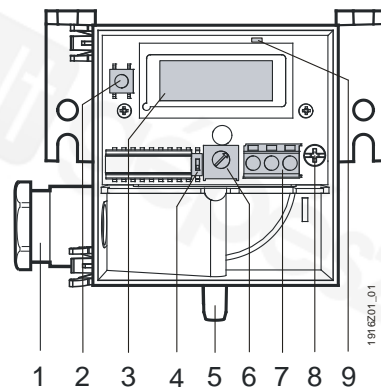

### Key

- 1 Cable entry gland Pg 11 with cable strain relief
- 2 Push-button for zero-point adjustment
- 3 LCD display (**QBM3020-..D** only), to digitally display the sensor signal in Pascal
- 4 DIP switch to change the characteristic (see "Set characteristic curve under "Commissioning notes")
- 5 Connection nipples (see "Mounting notes")
- 6 Potentiometer to set amplification at extracting-the-root output characteristic
- 7 Terminal block
- 8 Safety screw for hinged cover
- 9 LED for zero-point adjustment

## Engineering notes

---

The transformer used must be suited for safety extra low voltage (SELV). It must have separate windings and be designed for 100 % duty. Transformer size and fuse must comply with local safety regulations.

Observe maximum permissible cable lengths.

If cable lengths exceed 50 meters and run parallel to the mains cables: Use shielded cables!

## Mounting and Installation notes

---

The differential pressure sensor is suited for direct mounting on air ducts, walls, ceilings, or in control panels.

The supplied 2 meter plastic tubing can be modified to the duct connection on the plant. To achieve the housing protective class indicated under "Technical data", the differential pressure sensors must be mounted with the pressure nipple facing down. In addition, they should be higher than the air duct probes.

### Caution

**If the pressure connection nipples point upward or are at a lower level than the air duct probes, condensation can collect inside the sensor, causing damage to the device.**

### Note

The pressure tubing for the sensor nipples are connected as follows to the differential pressure sensors:

On the air duct side	On the pressure sensor side
Tubing with higher pressure side (lower vacuum)	Connect to pressure nipple "P1" or "+"
Tubing with lower pressure side (higher vacuum)	Connect to pressure nipple "P2" or "-"

The sensor is supplied with mounting instructions.

For detailed information on installation and mounting position, refer to the [Sensor Installation Guide](#) in BT download center.

### Caution

- Power supply by SELV or class 2 power supply with limited output of 15 W or less (UL requirement)
- Use only copper wiring

## Commissioning notes

### Caution



The values indicated under "Technical data" apply only to vertically mounted differential pressure sensors (connection nipples pointing down).

### Sensor calibration

Value deviations are possible for horizontal mounting (housing cover on top or bottom). These deviations can be compensated for by using the zero-point adjustment. See "Zero-point adjustment" below.

### Set characteristic curve

The settings of the characteristic curve (pressure-linear / extracting-the-root) using a DIP switch.

DIP switch	Characteristic curve
 *	Pressure-linear characteristic curve
	Extracting-the-root characteristic curve

\* Factory setting

### Zero-point adjustment

See also Display, setting and connection elements

1. Wiring connection terminals – Do not connect pressure tubing at this time.
2. Press the zero-point adjustment button for more than 2 seconds until the LED briefly lights up. The zero-point adjustment is additionally indicated on types with LCD displays with "0 Pa".  
A menu opens if you press the zero-point button for less than 2 seconds on LCD types. It closes automatically by multiple presses or a waiting period of 8 seconds.
3. Connect pressure tubing

## Disposal



The devices are considered electronics devices for disposal in terms of European Directive 2012/19/EU and may not be disposed of as domestic waste.

- Dispose of the device via the channels provided for this purpose.
- Comply with all local and currently applicable laws and regulations.

## Technical data

### Electrical interface

Power supply	Safety extra low voltage (SELV/PELV) or class 2 (UL)
Operating voltage	AC 24 V $\pm$ 15 %, 50/60 Hz or DC 13.5...33 V
Power consumption	<0.5 VA
Current draw	<10 mA
External supply line protection	Fuse slow max. 10 A or Circuit breaker max. 13 A Characteristic B, C, D according to EN 60898 or Power source with current limitation of max. 10 A
Output voltage	DC 0 ...10 V
Burden ( $R_{Load}$ )	>10 k $\Omega$
Output	Not galvanically separated, 3-wire connection, short-circuit proof, protected against reverse polarity

**Functional data**

Measuring range	refer to "Type summary"
Sensing element	Piezo-resistive (silicone membrane, ceramic bar)
Measuring accuracy at recommended mounting position and 20 °C ambient temperature	(FS = Full Scale)
<b>for QBM3020-10, -10D, -25, -25D</b>	
– Zero point, end value	<±0.7 % FS
– Sum from linearity, reproducible and hysteresis	<±0.6 % FS
– TC zero point	<±0.04 % FS/°C
– TC sensitivity	<±0.02 % FS/°C
<b>for QBM3020-5, -5D</b>	
– Zero point, end value	<±0.7 % FS
– Sum from linearity, reproducible and hysteresis	<±1 % FS
– TC zero point	<±0.04 % FS/°C
– TC sensitivity	<±0.05 % FS/°C
<b>for QBM3020-3, -3D</b>	
– Zero point, end value	<±0.7 % FS
– Sum from linearity, reproducible and hysteresis	<±1 % FS
– TC zero point	<±0.05 % FS/°C
– TC sensitivity	<±0.05 % FS/°C
<b>for QBM3020-1U, -1, -1D</b>	
– Zero point, end value	<±1 % FS
– Sum from linearity, reproducible and hysteresis	<±1 % FS
– TC zero point	<±0.1 % FS/°C
– TC sensitivity	<±0.06 % FS/°C
Long-term stability	±1,0% FS as per DIN IEC 60770
Response time	<20 ms
Load change	<10 Hz
Tolerable overload on one side	
At P1	5,000 Pa (10,000 Pa for types QBM3020-5, -10, -25 )
At P2	400 Pa
Rupture pressure	
0...70 °C	1.5 x overload
at room temperature	2 x overload
Display (on QBM3020-...D only)	LCD, 2-line, 8 position each, alphanumeric, not background lit
Display of	Differential pressure in Pa
Media	Air and non-aggressive gases
Admissible medium temperature	0...70 °C
Maintenance	Maintenance free

<b>Degree of protection</b>	Protection degree of housing	IP54 according to EN 60529
	Protection class	III according to EN 60730-1
<b>Connections</b>	Electrical connection	
	Screw terminals for cable lead	max. 1.5 mm <sup>2</sup> (wire or stranded wire) cable gland entry Pg 11
	Pressure connection	PVC nipples Ø 6.2 mm
<b>Environmental conditions</b>	Permissible ambient temperature	
	Operation	0...70 °C
	Transport and storage	-25...+70 °C
	Permissible ambient humidity	<90 % r. F. (without condensation)
<b>Directives, standards</b>	Product standard	EN 61326-1 Electrical equipment for measurement, control and laboratory use. EMC requirements. General requirements
	EU Conformity (CE)	CE1T1910xx_01 <sup>*)</sup>
	RCM Conformity	CE1T1910en_C1 <sup>*)</sup>
		UL 60730-1 / UL 60730-2-6 <a href="http://ul.com/database">http://ul.com/database</a>
	<b>Environmental compatibility</b>	The product environmental declaration CE1E1916 <sup>*)</sup> contains data on environmentally compatible product design and assessments (RoHS compliance, materials composition, packaging, environmental benefit, disposal).
<b>Dimensions (weight)</b>	Weight (with packaging), without display	0.183 kg
	Weight (with packaging), with display	0.196 kg

\*) The documents can be downloaded from <http://siemens.com/bt/download>.

## Connection terminals

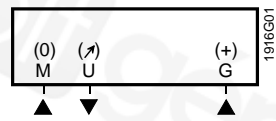

- G (+) Operating voltage AC 24 V or DC 13.5...33 V  
M (0) GND, measuring neutral  
U (⚡) Measuring signal DC 0...10 V

## Dimensions

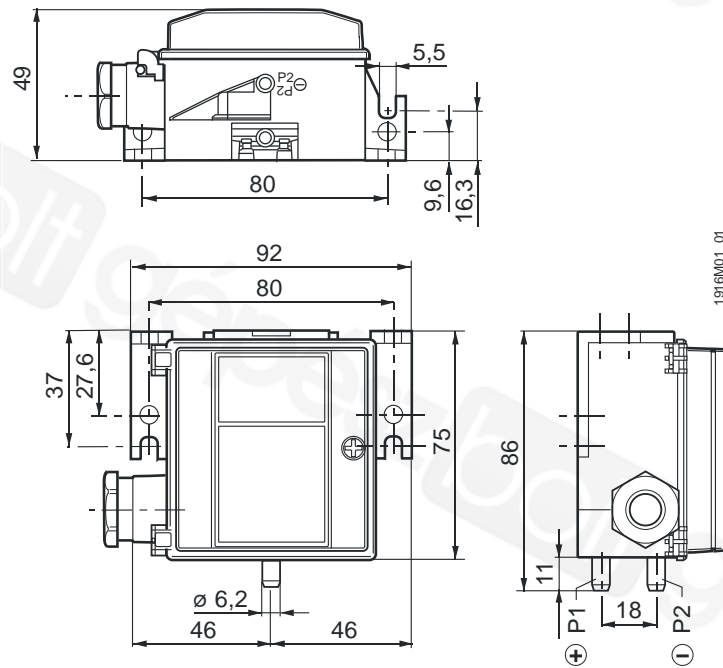

Dimensions in mm