



Synco™ living

## Meteo Sensor

## QAC910

- 
- **Wireless sensor for acquiring outside temperature and atmospheric pressure**
  - **RF communication based on KNX standard (868 MHz, unidirectional)**
  - **Battery-powered by commercially available 1.5 V batteries**

### Use

---

- For integration into the Siemens Synco living system
- Acquisition of outside temperature and atmospheric pressure in HVAC plant
- Especially suited for:
  - Renovation projects (old buildings, museums, churches, historical buildings, etc.)
  - Difficult wall-mounting situations (sandstone, glass, etc.)
  - New houses or buildings

## Equipment combinations

---

The QAC910 meteo sensor is designed for use with the Siemens Synco living system. For more detailed information about equipment combinations, refer to the Data Sheet covering the central apartment unit (CE1N2707en).

## Ordering

---

When ordering, please give quantity, product name and type reference.

### Scope of delivery

The QAC910 consists of outside sensor and RF transmitter. Each QAC910 is supplied complete with alkaline batteries, fixing material and Mounting Instructions.

Note Not included in the scope of delivery is the cable required for the connection between outside sensor and RF transmitter.

## Product documentation

---

The Operating and Commissioning Instructions for the QAC910 are contained in the product documentation of the central apartment unit.

## Functions

---

### Main function

In operation, the QAC910 forwards the acquired outside temperature and atmospheric pressure to the central apartment unit, either periodically or when changes occur.

### Binding

The binding is used by the QAC910 to sign on at the central apartment unit, thus ensuring integration into the RF system. The binding process is triggered via the multifunction button. It is indicated by the multifunction LED.

### Status query

The multifunction button can be used to query the batteries' capacity. Indication is by the multifunction LED.

### RF binding test

The multifunction button can be used to trigger a binding test. This test is made to check the radio link to the central apartment unit. The RF binding test is indicated by the multifunction LED.

### Error and maintenance messages

All error and maintenance messages are forwarded to the central apartment unit where they appear on the display.

The following messages are delivered by the QAC910:

Error messages	Maintenance message
Sensor error (failure of outside sensor)	Batteries exhausted (battery life $\leq$ 3 months)

## Operating and indicating elements

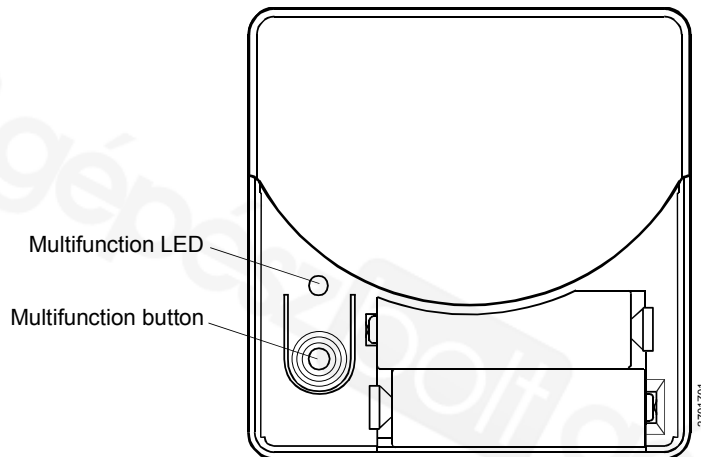

Overview of functions of the indicating and operating elements of the QAC910:

Multifunction LED	Multifunction button
<ul style="list-style-type: none"> <li>• Battery state</li> <li>• Binding process</li> </ul>	<ul style="list-style-type: none"> <li>• Battery state query</li> <li>• Binding</li> <li>• RF binding test</li> </ul>

For more detailed information about the functions and operation of the QAC910, refer to the product documentation covering the central apartment unit.

## Notes on engineering and operation

### Mounting location for outside sensor

- The outside sensor is to be mounted on an outer wall, at half the height of the house, at least 2.5 m above ground
- The outside sensor should be mounted on the coldest wall of the house (normally the North wall)

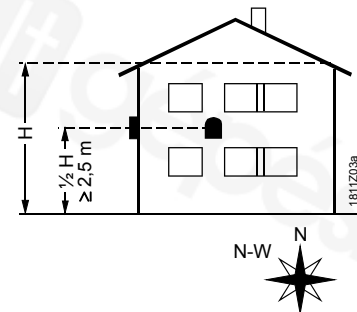

- Temperature acquisition must not be adversely affected by direct solar radiation, air drafts, or other heat or refrigeration sources
- The outside sensor must not be mounted:
  - Above windows, doors, air exhausts or other heat sources
  - Below balconies or eaves
- To avoid measuring errors due to air drafts, the end of the conduit at the sensor is to be sealed off with a grommet, cable gland or sealing compound
- The permissible environmental conditions must be observed

### Mounting location for RF transmitter

- The RF transmitter must be mounted inside the house or building
- It must not be exposed to dripping water and the permissible environmental conditions must be observed
- For notes relating to engineering and mounting RF devices of the Siemens Synco living system, refer to Data Sheet CE1N2708en.

- The base of the RF transmitter must be fitted on a flat wall
- Minimum clearance at the bottom should be 60 mm to ensure that the battery compartment is easily accessible

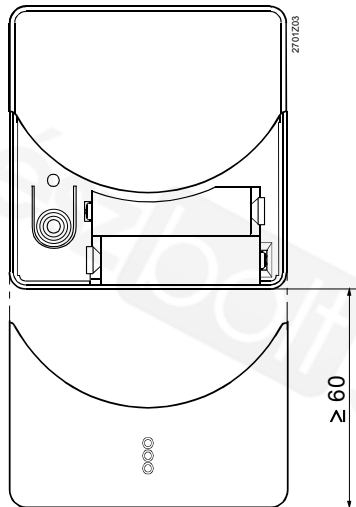

### Installation

Installation of both units with base for wall mounting:

The RF transmitter can be fitted to most commercially available conduit boxes or directly to the wall.

#### Note

Install the outside sensor first and then – inside the house – the RF transmitter. Then, connect the outside sensor to the RF transmitter (connecting cable not included). Only then may the batteries be inserted in the RF transmitter.

### Commissioning

Prior to commissioning, check to ensure that the outside sensor is correctly mounted on the recommended side of the building.

Also check to see if the cable is correctly connected to the respective terminals of both units and if the RF transmitter uses correctly working batteries.

### Maintenance / battery change

The QAC910 is maintenance-free.

The system indicates when batteries must be replaced. The batteries are located in the battery compartment of the RF transmitter. Batteries can be changed without removing the sensor from the wall and there is no need for using tools (reversed polarity protection).

### Disposal



In terms of disposal, the QAC910 is classified as electronic scrap conforming to the European Directive 2002/96/EG (WEEE) and must not be disposed of as domestic waste. The relevant national legal regulations must be complied with. The sensor must be disposed of through the relevant channels. Local and currently valid legislation must be observed. Exhausted batteries must be disposed of in compliance with environmental regulations.

### Warranty

Application-related technical data are only warranted in connection with the Siemens Synco living system. For equipment combinations, refer to the Data Sheet of the central apartment unit.

**When using the QAC910 together with third-party devices, correct functioning must be ensured by the user. In that case, Siemens will assume no responsibility for service and warranty.**

## Technical data QAC910 – outside sensor

Temperature sensor <sup>1)</sup>	Sensing element	NTC 1 kOhm resistor
	Measuring range	-50...50 °C
	Time constant	12 minutes

<sup>1)</sup> For a more detailed information, refer to CE1N1811E

## Technical data QAC910 – RF transmitter

Power supply	Type of battery	2 x alkaline batteries LR6 (AA) 1.5 V
	Battery life (capacity ≥ 2.5 Ah)	3 years
RF	Frequency	868 MHz (unidirectional)
	Range	typically 30 m inside buildings
	Protocol	KNX RF-compatible 
Pressure sensor	Sensing element	RS5534B (Intersema)
Electrical connection outside sensor	Screw terminals for	0.1...1.5 mm <sup>2</sup> (connections interchangeable)
	Permissible cable length	max. 10 m

Standards	<b>CE</b> -conformity to	
	EMC directive	2004/108/EC
	- Immunity, Emissions	- EN 60730-1
	Low-voltage directive	2006/95/EC
	- Electrical safety	- EN 60730-1
RTTE (Radio & Telecom. Equipment)		1999/5/EC
	- Wireless communication	- EN 300220-2, EN 301489-1, EN 301489-3

Protection	Safety class	III to EN 60730
	Housing	IP40 <sup>2)</sup> to EN 60529
	Degree of pollution	2 to EN 60730

Environmental compatibility	Environmental product declaration	ISO 14001 (Environment)
	CE1E2702en provides information on	ISO 9001 (Quality)
	environmentally compatible product design	SN 36350 (Environmentally compatible products)
	and assessment (RoHS compliance, composition of substances, packaging, environmental benefit and disposal)	2002/95/EC (RoHS)

Dimensions	refer to "Dimensions"	
Weight	Unit complete with accessories	0.331 kg
Housing material	plastic ASA+PC	
Housing color	white NCS S 0502-G	

Environmental conditions	operation	transport	storage
	IEC 60721-3-3	EN 60721-3-2	EN 60721-3-1
Climatic conditions	class 3K5	class 2K3	class 1K3
Temperature	0...+50 °C	-25...+70 °C	-20...+65 °C
Humidity	5...95 % r.h. (noncondensing)	<95 % r.h.	5...95 % r.h.
Mechanical conditions	class 3M2	class 2M2	class 1M2
Elevation above sea level	min. 700 hPa, corresponding to max. 3000 m above sea level		

<sup>2)</sup> Completely mounted

## Connection diagram

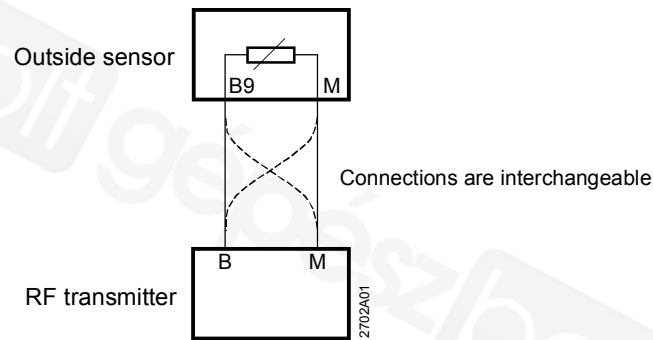

## Dimensions

Dimensions in mm

### Outside sensor

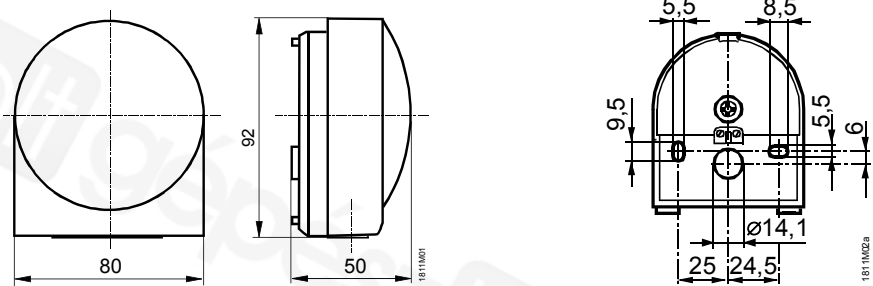

### RF transmitter

