

OpenAir™

VAV Compact Controller KNX / PL-Link

G..B181.1E/KN

**VAV Compact Controller 5 / 10 Nm with KNX communication**

- GDB181.1E/KN with 5 Nm nominal torque
- GLB181.1E/KN with 10 Nm nominal torque
- Operating voltage AC 24 V
- Supports KNX S-Mode, LTE-Mode, and PL-Link
- For plants with variable or constant air-volume flow
- Actual values for volume flow, damper position and differential pressure
- Operating modes for volume flow control or position control

Type summary

Product no.	Stock no.	Operating voltage	Positioning signal	Power consumption	Positioning time	Manual adjuster	Position feedback
GDB181.1E/KN	S55499-D134	AC 24 V	KNX-TP	1 VA / 0,5 W	150 s	Yes	Yes
GLB181.1E/KN	S55499-D135			3 VA / 2,5 W ¹⁾			

Please refer to data sheet **N4698** for information on accessories and spare parts.

¹⁾ Actuator rotates

Ordering (Example)

Product no.	Stock no.	Description	Amount
GDB181.1E/KN	S55499-D134	VAV Compact Controller KNX	1

Equipment combinations

Product no.	Stock no.	Description	Doc. number / reference
AST20	S55499-D165	Handheld tool for commissioning and service	A6V10631836
AST22	S55499-D373	USB/PPS2 Interface Converter	A6V11236956
ACS931	Software	PC Software for OEMs	N5853
ACS941	Software	PC Software for Service	N5852
ETS	Software	KNX Engineering Tool	www.knx.org
ACS790	Software	Synco Engineering Tool	CE1N5649
ABT Site	Software	Desigo Engineering/Commissioning Tool	A6V11159913

Software versions

VAV Compact Controllers series G are designed for using ETS device profile v2.x, however ETS device profile v1.x is supported for backward compatibility reasons.

Firmware / software version	Series E	Series F	Series G
Production period	10/2011 – 03/2014	03/2014 – 01/2017	01/2017
Bus module FW version	4.16	4.18	4.24
ETS device profile v1.x	supported	supported	supported
ETS device profile v2.x	not supported	not supported	supported

Product documentation

Title	Topic	Document ID
VAV Compact Controllers KNX / PL-Link – Technical Basics	Detailed information about the VAV compact controllers with KNX / PL-Link communication	P3547
Mounting Instruction VAV Compact Controllers KNX / PL-Link	Mounting / installation instruction for VAV compact controllers KNX / PL-Link 5 / 10 Nm	M3547

How to obtain documentation and product-related software

Related documents such as environmental declarations, CE declarations, etc., can be downloaded at the following Internet address:

<http://siemens.com/bt/download>

The ETS device profile can be downloaded at the following Internet address:

<http://siemens.com/hvac-td>

Limitations

VAV compact controllers are not suitable for environments where the air is saturated with sticky or fatty particles or contain aggressive substances.

Safety

⚠ Caution

National safety regulations

Failure to comply with national safety regulations may result in personal injury and property damage.

- Observe national provisions and comply with the appropriate safety regulations.

Mounting

- Do not open the damper actuators.
- Do not use the accessory mounting holes for fixation of the damper actuators.

Mounting positions

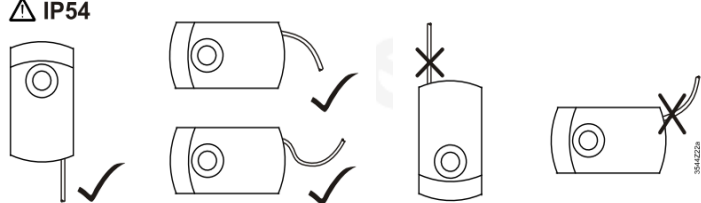
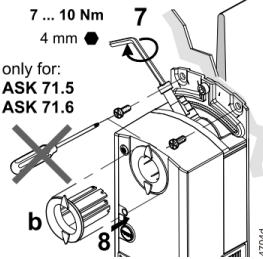
IP54 protection in following mounting positions	Accessory mounting holes ¹⁾
<p>⚠ IP54</p> 	<p>7 ... 10 Nm 4 mm ● 7</p> <p>only for: ASK 71.5 ASK 71.6</p>  <p><i>Cf. mounting instr. M3547</i></p>

⚠ ¹⁾ Not to be used for fixation of the actuator, use anti-rotation-bracket instead.

Maintenance

The damper actuators are maintenance-free.

Disconnect the electrical connections from the terminals if you want to work at the device.

Disposal



The device is considered electrical and electronic equipment for disposal in terms of the applicable European Directive and may not be disposed of as domestic garbage.

- Dispose of the device through channels provided for this purpose.
- Comply with all local and currently applicable laws and regulations.

Push-button operation

Activity	Push-button operation	Confirmation
Enter / leave addressing mode	Press button < 1s	LED turns red or turns off
Reset to factory settings	Press button > 20s	LED flashes orange until device restarts
PL-Link connection test ¹⁾	Press key >2s and < 20s	LED flashes 1x orange

¹⁾ Function or part of the function available in PL-Link operation only

LED colors and patterns

Color	Pattern	Description
Off	---	Fault free operation or device not powered
Green	steady	Connection test successful ¹⁾
Orange	flashing	a) Factory reset in progress b) When a connection test was triggered: wait ¹⁾
Red	steady	c) Device is in programming/addressing mode d) When a connection test was triggered: Connection test failed ¹⁾

¹⁾ Function or part of the function available in PL-Link operation only

Addressing and bus test with push button

The VAV compact controllers can be set into addressing/programming mode by push-button:

- Press push button (>0.1s and <1s)
- KNX bus wiring OK → LED turns red until addressing/programming is finished
- KNX bus wiring not OK → LED stays dark

Reset with push button

The VAV compact controllers can be reset to the OEM default values by push-button:

- Press push button > 20s → LED flashes orange → Device restarts

PPS2 programming interface (with AST20 or AST22)

For OEM factory programming or commissioning / maintenance tasks directly at the VAV compact controller, a suitable tool (cf. equipment combinations) can be connected to the PPS2 interface.

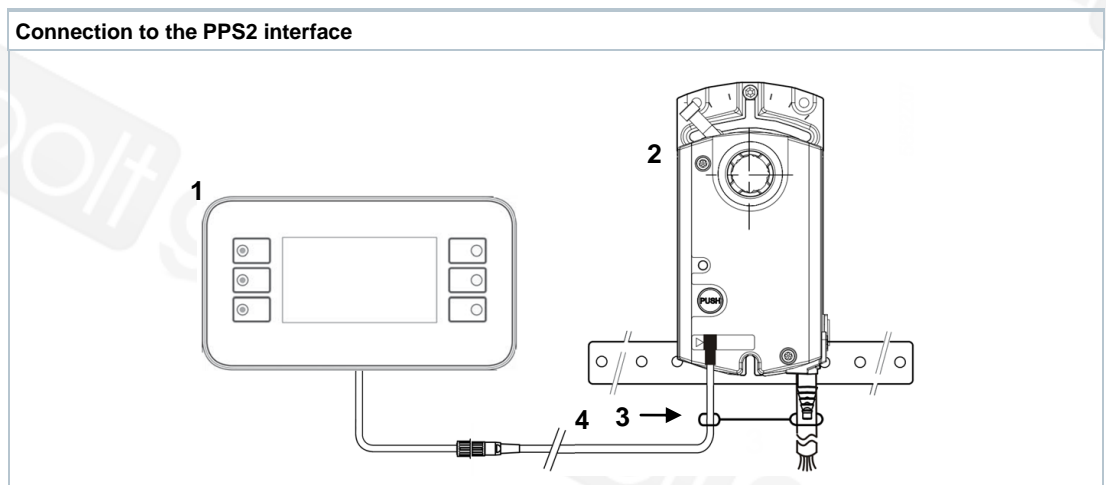

- 1 AST20 (or PC with ACS931 / ACS941 over AST22)
- 2 G..B181.1E/.. or ASV181.1E/3
- 3 Strain release strip
- 4 Connection cable (7-pin)

Volume flow control (VAV or CAV)

Variable air volume (VAV) control: the operating point is determined by the setpoint value and the Vmin / Vmax settings (cf. diagram below). Constant air volume (CAV) control is achieved by sending a constant setpoint or by setting Vmin = Vmax.

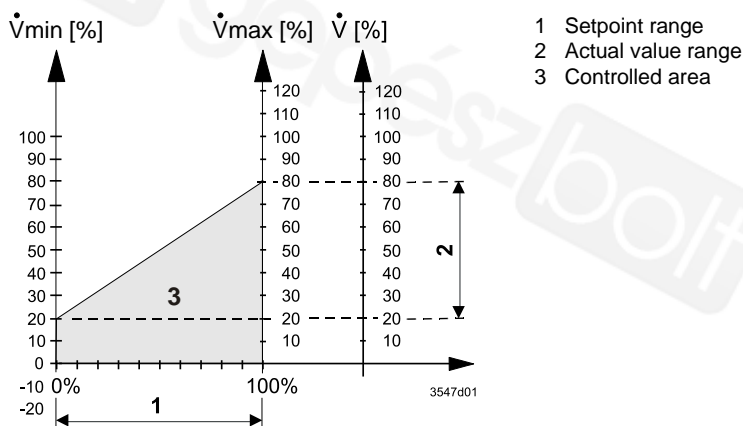

Position control

The VAV compact controllers can be operated as damper actuators, i.e. using the 0..100% setpoint as position damper setpoint, by setting the operating mode parameter to “POS”.

Commissioning and parameterization

Parameterization of the VAV application

VAV application parameters are set by the OEM over the PPS2 interface (using ACS931 or AST20). Some of them can be adjusted during commissioning, operation, or maintenance and are accessible over a bus connection alternatively.

Parameter	Range	Description	Factory settings
Operating mode	VAV / POS	VAV: setpoint = volume flow 0...100% POS: setpoint = damper position 0...100%	VAV
Opening direction	CW (R) / CCW (L)	Opening direction of air damper	CW (R)
Adaptive positioning	Off / On	Adaption of actual (if mech. limited) opening range to position feedback 0...100% Off = No adaption / On = Pos. adaption	Off
Vmin	-20...100%	Minimum air volume flow, rel. to Vnom	0 %
Vmax	20...120%	Maximum air volume flow, rel. to Vnom	100 %
Vnom	0...60'000 m ³ /h	Nominal air volume flow	100 m ³ /h
Box coefficient (Vn)	1...3.16	VAV box characteristic value, defined by the OEM	1.00
Altitude / Elevation asl.	0...5000m in 500m steps	Correction factor for diff. pressure sensor (select n*500m value closest to local altitude)	500 m

Parameterization of the KNX integration

KNX integration parameters are checked or set during engineering and commissioning in the ETS engineering tool.

Parameter	Range	Description	Factory settings
Tab card "standard"			
Operating mode	VAV / POS	VAV: setpoint = volume flow 0...100% POS: setpoint = damper position 0...100%	VAV
Adaptive positioning	On / Off	Adaption of actual (if mech. limited) opening range to position feedback 0...100% Off = No adaption / On = Pos. adaption	Off
Altitude / Elevation asl.	0...5000m in 500m steps	Correction factor for diff. pressure sensor (select n*500m value closest to local altitude)	500 m
Backup timeout	0..60 min 0 min = disabled	Time interval to detect communication interruption. If disabled, the actuator drives to the last received setpoint until a new setpoint is received.	30 min.
Backup mode	Backup position Keep last position	Actuator behavior when the communication timeout has been exceeded (no setpoint received within the defined time interval). <ul style="list-style-type: none"> ▪ Backup position: Actuator drives to defined position ▪ Keep last position: Actuator keeps position without flow control 	Backup position
Backup position	0...100%	Position the damper drives to in case of communication interruption	50%
Tab card "advanced"			
Hysteresis (COV) ¹⁾ volume flow	1...20%	Threshold for the relative volume flow. COV below this value are not sent over the bus.	1%
Min. repetition time volume flow	10...900 s	Minimum waiting time until a COV above the hysteresis threshold is sent over the bus	10 s
Hysteresis (COV) damper position	1...20%	Threshold for the damper position. COV below this value are not sent over the bus	1%
Min. repetition time damper position	10...900 s	Minimum waiting time until a COV above the hysteresis threshold is sent over the bus	10 s
Override position 1 ²⁾	0...100%	Damper position which can be triggered by the corresponding group object	0%
Override position 2 ²⁾	0...100%	Damper position which can be triggered by the corresponding group object	100%
Write Vnom	On / Off	If checked, the group object for Vnom is writable (OEM parameter protection applies), otherwise it is read-only.	Off
Write Opening Direction	On / Off	If checked, the group object for the opening direction is writable (OEM parameter protection applies), otherwise it is read-only.	Off

¹⁾ COV = Change of value

²⁾ Override position 1 has priority over Override position 2

Group Objects Table

Nr.	Name in ETS	Object function	Flags					Data point type KNX				Range
			C	R	W	T	U	ID	DPT_Name	Format	Unit	
1	Fault information	Transmit	1	1	0	1	0	219.001	_AlarmInfo	6 Byte	---	cf. Group Objects Descr.
2	Fault state	Transmit	1	1	0	1	0	1.005	_Alarm	1 bit	---	0 = No alarm / 1 = Alarm
3	Fault transmission	Receive	1	0	1	0	1	1.003	_Enable	1 bit	---	0 = Disable / 1 = Enable
4	Setpoint	Receive	1	1	1	0	1	5.001	_Scaling	1 Byte	%	0...100%
5	Damper position	Transmit	1	1	0	1	0	5.001	_Scaling	1 Byte	%	0...100%
6	Volume flow relative ¹⁾	Transmit	1	1	0	1	0	5.001	_Scaling	1 Byte	%	0...100%
		Transmit	1	1	0	1	0	8.010	_Percent_V16	2 Bytes	%	-327.68...327.67%
		Transmit	1	1	0	1	0	5.004	_Percent_U8	1 Byte	%	0...255%
7	Volume flow absolute ¹⁾	Transmit	1	1	0	1	0	9.009	_Value_Airflow	2 Bytes	m ³ /h	-670 760...670 760 m ³ /h
		Transmit	1	1	0	1	0	14.077	_Volume_Flux	4 Bytes	m ³ /s	0...(2 ³² -1)
8	Fault	Transmit	1	1	0	1	0	1.005	_Alarm	1 bit	---	0 = No alarm / 1 = Alarm
9	Overridden	Transmit	1	1	0	1	0	1.002	_Bool	1 bit	---	0 = False / 1 = True
10	Override position 1	Receive	1	1	1	0	1	1.003	_Enable	1 bit	---	0 = Disable / 1 = Enable
11	Override position 2	Receive	1	1	1	0	1	1.003	_Enable	1 bit	---	0 = Disable / 1 = Enable
12	Balancing mode	Receive	1	1	1	0	0	1.003	_Enable	1 bit	---	0 = Disable / 1 = Enable
13	Vmin	Receive	1	1	1	0	1	8.010	_Percent_V16	2 Bytes	%	-327.68...327.67%
14	Vmax	Receive	1	1	1	0	1	8.010	_Percent_V16	2 Bytes	%	-327.68...327.67%
15	Vnom	Read-only	1	1	0	0	0	9.009	_Value_Airflow	2 Bytes	m ³ /h	-670 760...670 760 m ³ /h
16	Opening direction	Read-only	1	1	0	0	0	1.012	_Invert	1 bit	---	0 = Not Inverted / 1 = Inv.
17	Diff. pressure ¹⁾	Read-only	1	1	0	0	0	9.006	_Value_Pres	2 Bytes	Pa	0...670 760 Pa
		Read-only	1	1	0	0	0	14.058	_Value_Pressure	4 Bytes	Pa	0...(2 ³² -1)
18	Coefficient	Read-only	1	1	0	0	0	14.*	4-Byte Float	4 Bytes	---	0...3.16
19	OEM-Reset	Receive	1	0	1	0	0	1.017	_Trigger	1 bit	---	0, 1 = Trigger

¹⁾ For some group objects, alternative data point types (DPT) can be selected in ETS. The first entry indicates the default setting.

Group Objects Description

- 1 Fault information If group object #3 "fault transmission" is set to "on", the following faults can be transmitted if they occur. In that case, group object #2 value changes to "alarm".

Error	Group obj. #1	Description	Resolution
Device jammed	03 00 0A 03 0C 05	Target position can't be reached due to blockage.	Remove blockage (visual inspection required) or invert Opening direction, if it is set wrongly Or switch on adaptive positioning, if mechanical limits are intended.
Backup mode entered	00 01 01 02 0C 05	Actuator is in backup mode (cf. respective parameter setting)	Actuator leaves Backup mode when receiving a setpoint.
Pressure sensor tubes inverted	00 01 0A 01 0C 05	Pressure sensor measures the lower pressure on the input marked with "+".	Correct the tubes connection
Pressure sensor malfunction	00 01 0A 01 0C 05	Malfunction of internal communication to dp sensor (200 ms timeout)	1) Check tubes connection, or 2) reboot device, or 3) replace device
Operating hours notification	00 01 0A 04 0C 05	Appears after a cumulated motor running time of 365 days	Check device status and control loop sensitivity

- 2 Fault state Indicates whether the actuator is in fault state. If yes, read out group object #1.
- 3 Fault transmission Enabling/ disabling the fault transmission. Fault transmission is disabled by default; therefore no faults are transmitted from the actuator over the KNX bus.
- 4 Setpoint Setpoint 0...100% for volume flow or position, depending on the operating mode.
- 5 Damper position Relative damper position 0...100%. An opening range less than 0...90° can be normalized to 0...100% if adaptive positioning is set to "on".
- 6 Volume flow relative Volume flow relative to the settings of Vnom, Vmin, and Vmax.
- 7 Volume flow absolute Volume flow in m³/h or m³/s depending on the selected data type.
- 8 Fault Same function as group object #2 (available for compatibility reasons).
- 9 Overridden Indicates whether the VAV controller is in override control either by a programming tool connected to the HMI or by objects #10 / #11.
- 10 Override position 1 When the object is triggered, the actuator drives to the override position 1 defined by the respective ETS parameter.
- 11 Override position 2 When the object is triggered, the actuator drives to the override position 2 defined by the respective ETS parameter.
- 12 Balancing mode When the object is triggered, the actuator drives to Vmax for air balancing purposes.
- 13 Vmin Minimum air volume flow relative to Vnom.
- 14 Vmax Maximum air volume flow relative to Vnom.
- 15 Vnom Nominal air volume flow (absolute).
- 16 Opening direction Opening direction of the air damper.
- 17 Diff. pressure Actual value of the differential pressure over the VAV box measuring cross.
- 18 Coefficient VAV box characteristic value to map a nominal differential pressure to the corresponding nominal volume flow.
- 19 OEM-Reset Resets all parameters to the value specified by the OEM.

Technical data

Power supply		
Operating voltage	G..B181.1E/..	AC 24 V ± 20 % (SELV) or AC 24 V class 2 (US)
Frequency		50/60 Hz
Power consumption	at 50 Hz	
	Actuator holds	1 VA / 0.5 W
	Actuator rotates	3 VA / 2.5 W
Function data		
Positioning time for nominal rotation angle	G..B181.1E/..	150 s (50 Hz) 125 s (60 Hz)
Nominal torque	GDB..	5 Nm
	GLB..	10 Nm
Maximum torque	GDB..	< 7 Nm
	GLB..	< 14 Nm
Nominal / maximum rotation angle		90° / 95° ± 2°
Direction of rotation	Adjustable by tool or over bus	Clockwise (CW) / Counter-clockwise (CCW)
Connection cables		
Cable length		0.9 m
Power supply	Number of cores and cross-sectional area	2 x 0.75 mm ²
Communication	Number of cores and cross-sectional area	2 x 0.75 mm ²
Service interface	Terminal strip	7-pin, grid 2.00 mm
Communication		
Communication protocol	Connection type	KNX-TP (galvanically isolated)
	Bus load	5 mA
Degree of protection		
Degree of protection	Degree of protection acc. to EN 60529 (see mounting instruction)	IP54
Safety class	Safety class acc. to EN 60730	III
Environmental conditions		
Applicable standard		IEC 60721-3-x
Operation	Climatic conditions	Class 3K5
	Mounting location	Indoors
	Temperature general	0...50 °C
	Humidity (non condensing)	5...95 % r. F.
Transport	Climatic conditions	Class 2K3
	Temperature	-25...70 °C
	Humidity	5...95 % r. h.
Storage	Climatic conditions	Class 1K3
	Temperature	-5...45 °C
	Humidity	5...95 % r. h.

Directives and Standards		
Product standard	EN60730-x	
Electromagnetic compatibility (Application)	For residential, commercial and industrial environments	
	GDB181.1E/KN	GLB181.1E/KN
EU Conformity (CE)	A5W00003842 ¹⁾	A5W00000176 ¹⁾
RCM Conformity	A5W00003843 ¹⁾	A5W00000177 ¹⁾
UL, cUL	AC 24 V	UL 873 http://ul.com/database
Environmental compatibility		
The product environmental declaration A6V10209938 ¹⁾ contains data on environmentally compatible product design and assessments (RoHS compliance, materials composition, packaging, environmental benefit, disposal).		
Dimensions / Weight		
Weight	Without packaging	0.6 kg
Dimensions	71 x 158 x 61 mm	
Suitable drive shafts	Round shaft (with centering element)	8...16 mm (8...10 mm)
	Square shaft	6...12.8 mm
	Min. drive shaft length	30 mm
	Max. shaft hardness	<300 HV
Air volume flow controller		
Type	3-position controller with hysteresis	
V _{max} , adjustable	resolution 1% / factory setting 100%	20%...120%
V _{min} , adjustable	resolution 1% / factory setting 0%	-20%...100%
V _n = f(dp _n), adjustable	resolution 0.01 / factory setting 1.00	1.0...3.16
Differential pressure sensor		
	Connection tubes (Interior diameter)	3...8 mm
	Measuring range	0...500 Pa
	Operating range	0...300 Pa
Precision at 23 °C, 966 mbar and optional mounting position	Zero point	± 0.2 Pa
	Amplitude	± 4.5 % of the measured value
	Drift	± 0.1 Pa / Year
	Max. permissible operating pressure	3000 Pa
	Max. permissible overload on one side	3000 Pa

¹⁾ The documents can be downloaded from <http://siemens.com/bt/download>

Diagrams

Internal diagrams

The VAV compact controller is supplied with two prewired connecting and communication cables.

G..B181.1E/KN

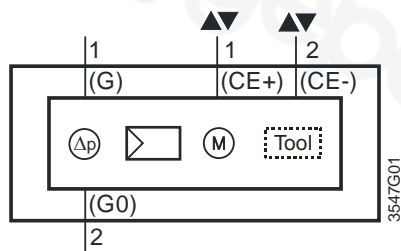

Tool = Configuration and maintenance interface
(Series E and later: 7-pin connector)

Power supply and communication cables

Core designation	Core color	Terminal code	Description
Cable 1: Power / black sheathing			
1	red (RD)	G	System voltage AC 24 V
2	black (BK)	G0	System neutral AC 24 V
Cable 2: Communication / green sheathing			
1	red (RD)	CE+	KNX CE+
2	black (BK)	CE-	KNX CE+

Note

The operating voltage at terminals G and G0 must comply with the requirements under SELV or PELV.

Safety transformers with twofold insulation as per EN 61558 required; they must be designed to be on 100 % of the time.

Dimensions

G..B181.1E/..

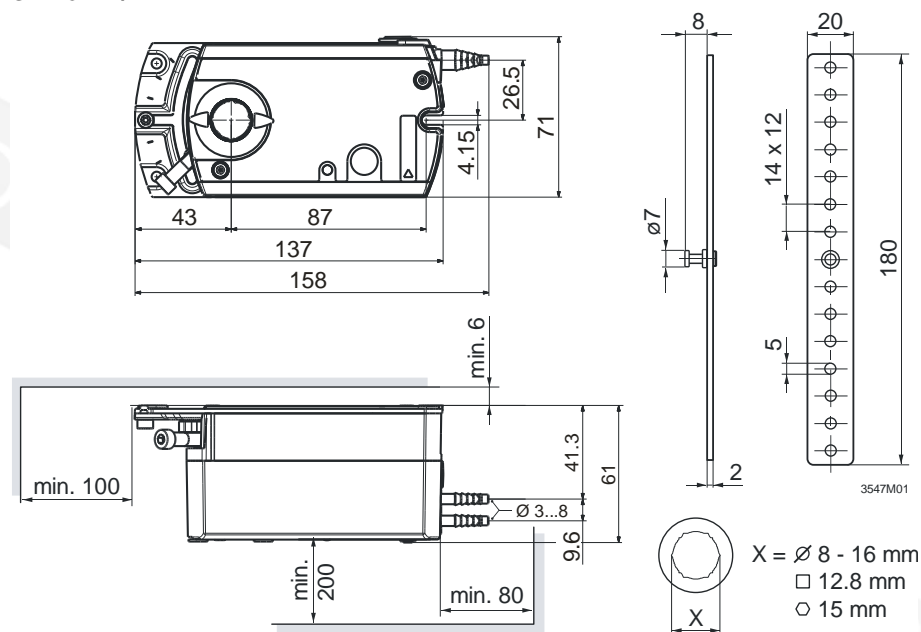

Measurements in mm

gépészbolt gépészbolt gépészbolt gépészbolt
gépészbolt gépészbolt gépészbolt gépészbolt
gépészbolt gépészbolt gépészbolt gépészbolt
gépészbolt gépészbolt gépészbolt gépészbolt

Issued by
Siemens Switzerland Ltd
Building Technologies Division
International Headquarters
Theilerstrasse 1a
6300 Zug
Switzerland
Tel. +41 58-724 24 24
www.siemens.com/buildingtechnologies

© Siemens Switzerland Ltd, 2017
Technical specifications and availability subject to change without notice.

Document ID CE1N3547en_d
Edition 2016-11-20